

# 241-84 BACK

REVISIONS		
REV.	DESCRIPTION	DATE
01		
02		
03		
04		
05		

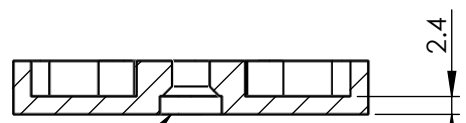
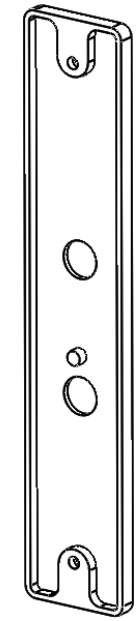
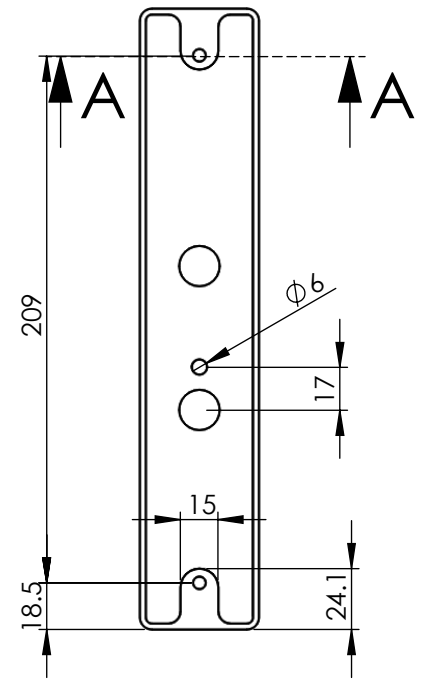
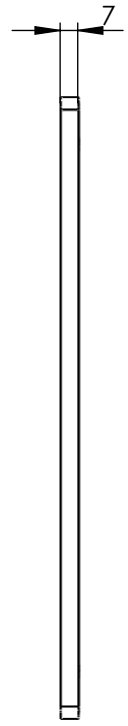
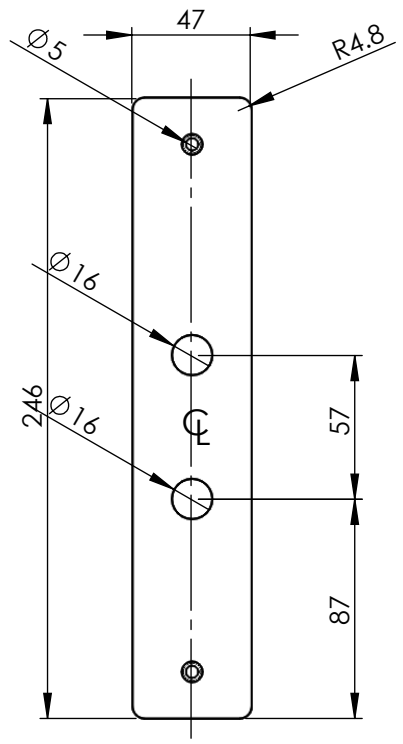

COUNTERSINK FOR M5x0.8 SCREW  
**SECTION A-A**  
 SCALE 1 : 1

**PROPRIETARY AND CONFIDENTIAL**  
 THE INFORMATION CONTAINED IN THIS DRAWING IS THE SOLE PROPERTY OF AHI HARDWARE. ANY REPRODUCTION IN PART OR AS A WHOLE WITHOUT THE WRITTEN PERMISSION OF AHI HARDWARE IS PROHIBITED.

**UNLESS OTHERWISE SPECIFIED:**  
 DIMENSIONS ARE IN mm  
 TOLERANCES:  
 FRACTIONAL  
 ANGULAR: MACH BEND  
 TWO PLACE DECIMAL  
 THREE PLACE DECIMAL

	NAME	DATE
DRAWN	FD	19/09/2017
CHECKED		
ENG APPR.		
MFG APPR.		
Q.A.		
COMMENTS:		

**A H I H A R D W A R E**

**TITLE:**  
241-84

**DWG. NO.**  
241-84

**SCALE:** 1:3

**SHEET 1 OF 2**

\\WDMYCL0UD\our\AHI\BACK PLATES\241-84

# 241-84 FRONT

REVISIONS		
REV.	DESCRIPTION	DATE
01		
02		
03		
04		
05		

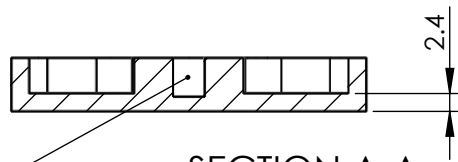
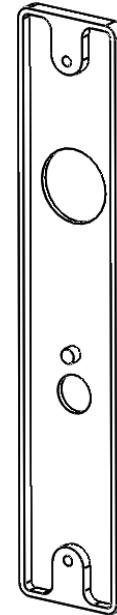
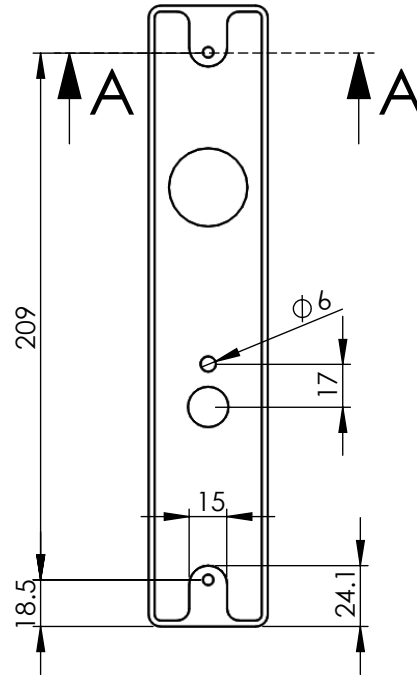
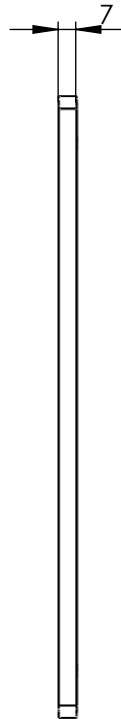
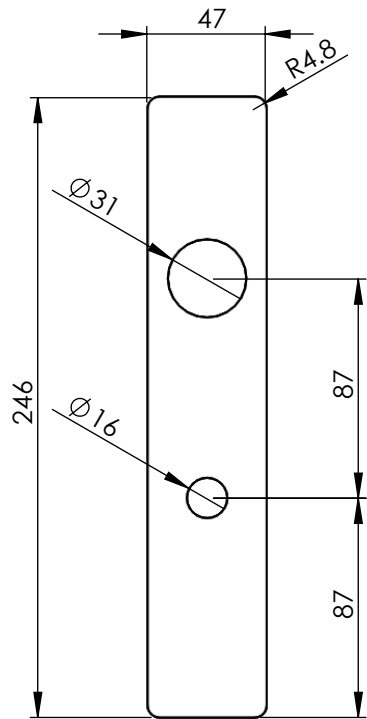

TAP M5x0.8

SECTION A-A  
SCALE 1:1

**PROPRIETARY AND CONFIDENTIAL**

THE INFORMATION CONTAINED IN THIS DRAWING IS THE SOLE PROPERTY OF AHI HARDWARE. ANY REPRODUCTION IN PART OR AS A WHOLE WITHOUT THE WRITTEN PERMISSION OF AHI HARDWARE IS PROHIBITED.

**UNLESS OTHERWISE SPECIFIED:**

DIMENSIONS ARE IN mm  
TOLERANCES:  
FRACTIONAL  
ANGULAR: MACH BEND  
TWO PLACE DECIMAL  
THREE PLACE DECIMAL

	NAME	DATE
DRAWN	FD	19/09/2017
CHECKED		
ENG APPR.		
MFG APPR.		
Q.A.		
COMMENTS:		

**A H I H A R D W A R E**

TITLE:  
241-84

DWG. NO.  
241-84

SCALE: 1:3

SHEET 2 OF 2

\\WDMYCL00D\our\AHI\BACK PLATES\241-84